



Weyn-Lauwers N.V.

Industriepark-Noord 12
B - 9100 SINT-NIKLAAS

Tel. : 00 32 (0)3 776.34.13
Fax : 00 32 (0)3 778.09.52
weynlauwers@weynlauwers.be
www.weynlauwers.be

**BALL VALVE
PN16/40 - FULL BORE
CARBON STEEL LF2
FIG 163 DN15-DN200**

DESIGN FEATURES

- 2-PC carbon steel ball valve DN15 - DN200
- Flanges acc. DIN2501 PN16/40
- min. : -20°C +180°C
- face to face acc. DIN3202 F4/F5
- specifications :
 - anti-blow out stem
 - locking device / full bore
 - FIRE-SAFE / DVGW upto DN100
 - mounting pad acc. ISO 5211

USE

- for all common fluids / GAS
- max. pressure : DN15-DN50 : PN16/40
DN65-DN200 : PN16

MATERIALS

item	Part name	Material
1	Body	LF2
2	Flange	LF2
3	Ball	SS 304
4	Stem	SS 304
5	Ball seat	PTFE
6	Body sealing ring	PTFE
8	upper sealing ring	PTFE
9	stem O-ring	VITON
10	upper sealing couple	PTFE
11	gland washer	SS 304
13	belleville washers	50CrV4
14	stem retaining nut	CS
17	locking nut	CS
18	lever	CS
35	stop pin	CS
36	stud bolt	CS
37	nut	CS

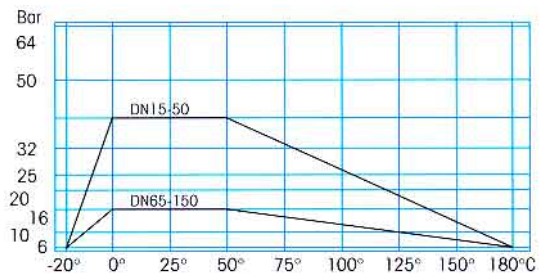
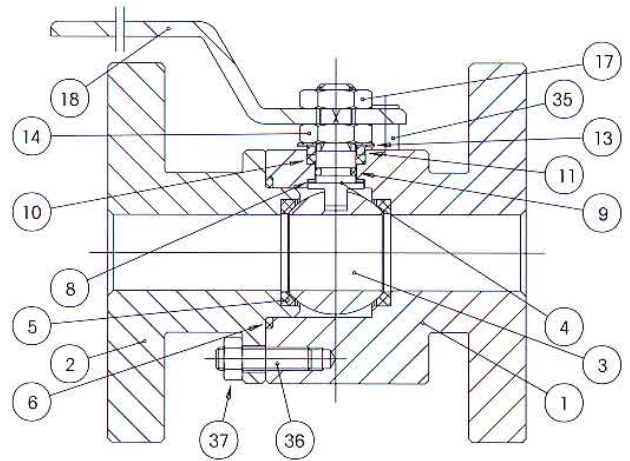

SIZE (in mm)

size	ref	B	D	E	F	L	ISO	kg
DN 15	205731	66	140	34	15	115	F03	3,6
DN 20	205732	69	140	54	20	120	F03	4,7
DN 25	205733	82	180	39	25	125	F04	5,8
DN 32	205734	87	180	46	32	130	F04	8,4
DN 40	205735	108	230	57	40	140	F05	11,2
DN 50	205736	115	230	65	50	150	F05	14,9
DN 65	205737	139	320	80	65	170	F07	23,8
DN 80	205738	150	320	91	78	180	F07	28,6
DN100	205739	163	370	121	96	190	F10	35,6
DN125	205740	181	370		118	325	F10	65,6
DN150	205741	249	584		144	350	F12	108,9
DN200	205742	288	584		192	400	F12	194,7

